

## Description

GM66102 of positive fixed and adjustable regulators is designed to provide up to 1A output with high current, high accuracy, and extremely low dropout voltage performance. These regulators feature 300 to 350mV (full load) dropout voltages and very low ground current. Although designed for high current, and loads, these devices are also useful in lower current, extremely low dropout-critical systems, where their minimal dropout voltage and ground current values are important characteristics.

GM66102 is fully protected against overcurrent, reversed input polarity (or reversed battery connection), reversed lead insertion, over-temperature operation, and transient voltage spikes (positive or negative). GM66102 is available in TO-220, SOT-223, TO-252 and TO-263 packages.

## Features

- ◆ Fixed and Adjustable Voltage Versions
- ◆ Output Current up to 1A
- ◆ Low Dropout Voltage 350mV @ 1A
- ◆ Low Ground Current
- ◆ Accurate 1% Guaranteed Tolerance
- ◆ Extremely Fast Transient Response
- ◆ Reverse-battery Protection
- ◆ "Load Dump" Protection
- ◆ Extremely Fast Transient Response

## Application

High Efficiency Linear Regulators  
Post Regulators for Switching Supplies

Battery Powered Equipment  
Automotive Electronics

## TYPICAL APPLICATION CIRCUITS

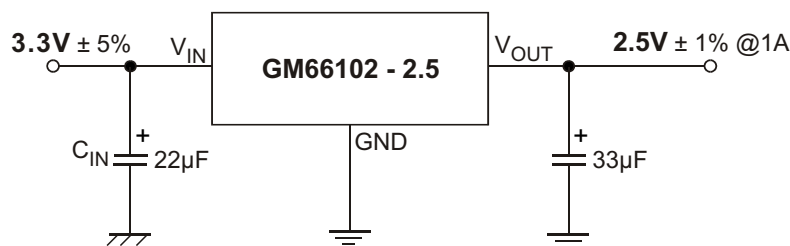

$C_{IN}$  is required if regulator is located an appreciable distance from power supply filter.

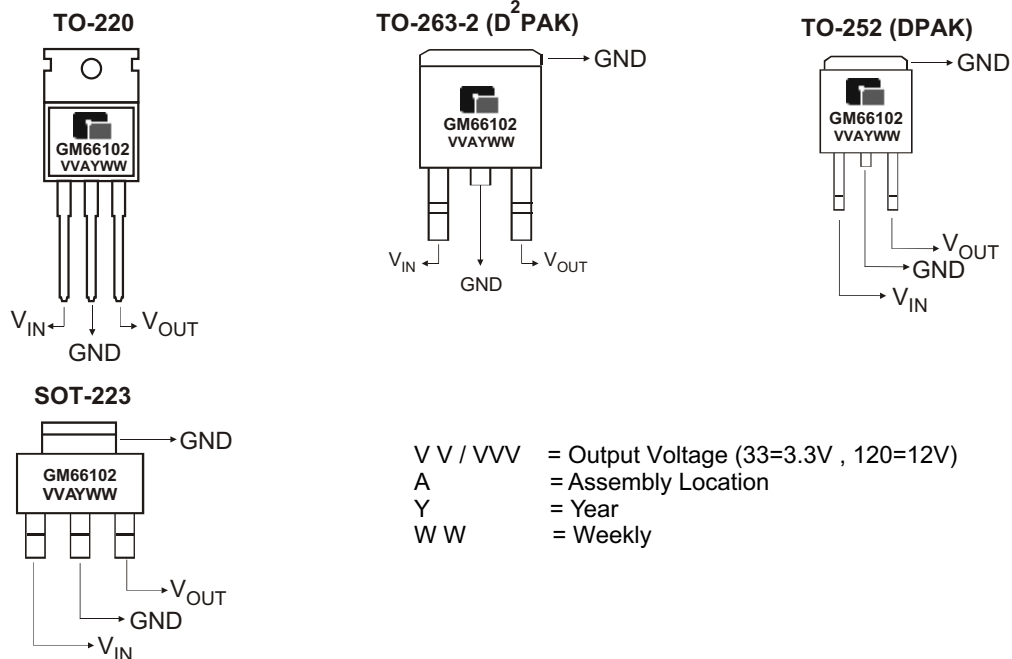
**◆ MARKING INFORMATION & PIN CONFIGURATIONS(TOP VIEW)**

**◆ ORDERING INFORMATION**

Ordering Number	Output Voltage	Package	Shipping
GM66102-1.5TB3T	1.5V	TO-220	50 Units/ Tube
GM66102-1.5ST3T	1.5V	SOT-223	80 Units/ Tube
GM66102-1.5ST3R	1.5V	SOT-223	2,500 Units/ Tape & Reel
GM66102-1.5TC3T	1.5V	TO-252	80 Units / Tube
GM66102-1.5TC3R	1.5V	TO-252	2,500 Units/ Tape & Reel
GM66102-1.5TA3T	1.5V	TO-263-2	50 Units / Tube
GM66102-1.5TA3R	1.5V	TO-263-2	800 Units/ Tape & Reel
GM66102-1.8TB3T	1.8V	TO-220	50 Units/ Tube
GM66102-1.8ST3T	1.8V	SOT-223	80 Units/ Tube
GM66102-1.8ST3R	1.8V	SOT-223	2,500 Units/ Tape & Reel
GM66102-1.8TC3T	1.8V	TO-252	80 Units / Tube
GM66102-1.8TC3R	1.8V	TO-252	2,500 Units/ Tape & Reel
GM66102-1.8TA3T	1.8V	TO-263-2	50 Units / Tube
GM66102-1.8TA3R	1.8V	TO-263-2	800 Units/ Tape & Reel
GM66102-2.5TB3T	2.5V	TO-220	50 Units/ Tube
GM66102-2.5ST3T	2.5V	SOT-223	80 Units/ Tube
GM66102-2.5ST3R	2.5V	SOT-223	2,500 Units/ Tape & Reel
GM66102-2.5TC3T	2.5V	TO-252	80 Units / Tube
GM66102-2.5TC3R	2.5V	TO-252	2,500 Units/ Tape & Reel
GM66102-2.5TA3T	2.5V	TO-263-2	50 Units / Tube
GM66102-2.5TA3R	2.5V	TO-263-2	800 Units/ Tape & Reel

\* For detail Ordering Number identification, please see last page.

◆ ORDERING INFORMATION (Continued)

Ordering Number	Output Voltage	Package	Shipping
GM66102-3.0TB3T	3.0V	TO-220	50 Units/ Tube
GM66102-3.0ST3T	3.0V	SOT-223	80 Units/ Tube
GM66102-3.0ST3R	3.0V	SOT-223	2,500 Units/ Tape & Reel
GM66102-3.0TC3T	3.0V	TO-252	80 Units/ Tube
GM66102-3.0TC3R	3.0V	TO-252	2,500 Units/ Tape & Reel
GM66102-3.0TA3T	3.0V	TO-263-2	50 Units/ Tube
GM66102-3.0TA3R	3.0V	TO-263-2	800 Units/ Tape & Reel
GM66102-3.3TB3T	3.3V	TO-220	50 Units/ Tube
GM66102-3.3ST3T	3.3V	SOT-223	80 Units/ Tube
GM66102-3.3ST3R	3.3V	SOT-223	2,500 Units/ Tape & Reel
GM66102-3.3TC3T	3.3V	TO-252	80 Units/ Tube
GM66102-3.3TC3R	3.3V	TO-252	2,500 Units/ Tape & Reel
GM66102-3.3TA3T	3.3V	TO-263-2	50 Units/ Tube
GM66102-3.3TA3R	3.3V	TO-263-2	800 Units/ Tape & Reel
GM66102-5.0TB3T	5.0V	TO-220	50 Units/ Tube
GM66102-5.0ST3T	5.0V	SOT-223	80 Units/ Tube
GM66102-5.0ST3R	5.0V	SOT-223	2,500 Units/ Tape & Reel
GM66102-5.0TC3T	5.0V	TO-252	80 Units/ Tube
GM66102-5.0TC3R	5.0V	TO-252	2,500 Units/ Tape & Reel
GM66102-5.0TA3T	5.0V	TO-263-2	50 Units/ Tube
GM66102-5.0TA3R	5.0V	TO-263-2	800 Units/ Tape & Reel
GM66102-12TB3T	12V	TO-220	50 Units/ Tube
GM66102-12ST3T	12V	SOT-223	80 Units/ Tube
GM66102-12ST3R	12V	SOT-223	2,500 Units/ Tape & Reel
GM66102-12TC3T	12V	TO-252	80 Units/ Tube
GM66102-12TC3R	12V	TO-252	2,500 Units/ Tape & Reel
GM66102-12TA3T	12V	TO-263-2	50 Units/ Tube
GM66102-12TA3R	12V	TO-263-2	800 Units/ Tape & Reel

\* For detail Ordering Number identification, please see last page.

### ◆ ABSOLUTE MAXIMUM RATINGS

PARAMETER	SYMBOL	Value	UNIT
Power Dissipation	$P_D$	Internally limited	W
Input Supply Voltage (Note 1.)	$V_{IN}$	-20 to +60	V
Lead Temperature (Soldering, 5 sec)	$T_{LEAD}$	260	°C
Storage Temperature Range	$T_{STG}$	-65 to +150	°C

### ◆ OPERATING RATINGS

PARAMETER	SYMBOL	Value	UNIT
Maximum Operating Input Voltage	$V_{IN}$	26	V
Operating Junction Temperature Range	$T_J$	-40 to +125	°C
Thermal Resistance (Junction to case)	$R_{JC}$	15	°C/W
TO- 223		6.0	
TO- 252		2.0	
TO- 263		2.0	
TO- 220			

### ◆ BLOCK DIAGRAM

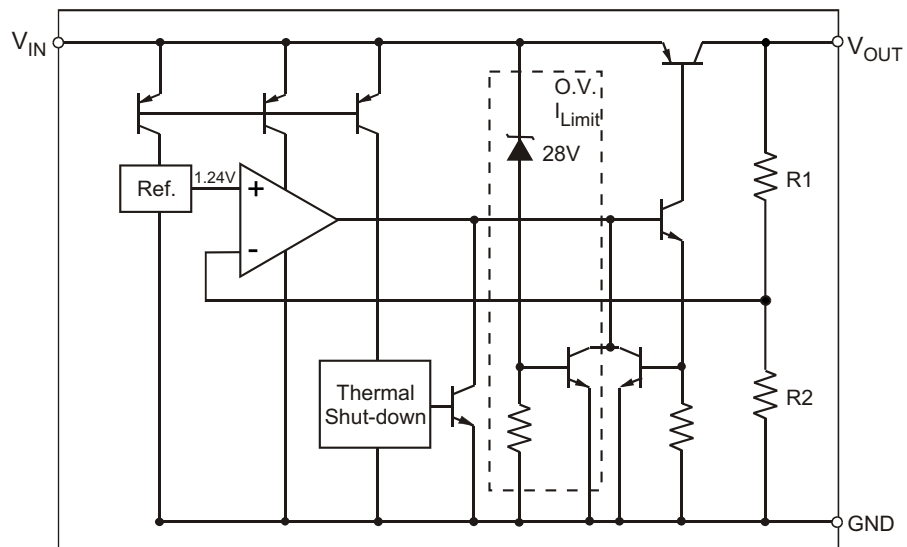

**◆ ELECTRICAL CHARACTERISTICS (T<sub>A</sub> = 25°C unless otherwise noted)**

 Unless otherwise specified: T<sub>J</sub> = 25°C; **Bold** values are guaranteed across the operating temperature range.

Parameter	Conditions	Min	Typ	Max	Unit
Output Voltage (Note2)	I <sub>O</sub> = 10 mA	-1		1	%
	10mA ≤ I <sub>O</sub> ≤ I <sub>FL</sub> , (V <sub>OUT</sub> + 1V) ≤ V <sub>IN</sub> ≤ 26V	<b>-2</b>		<b>2</b>	%
Line Regulation	I <sub>O</sub> = 10mA, (V <sub>OUT</sub> + 1V) ≤ V <sub>IN</sub> ≤ 26V		0.06	0.5	%
Load Regulation	V <sub>IN</sub> = V <sub>OUT</sub> + 5V, 10mA ≤ I <sub>OUT</sub> ≤ I <sub>FL</sub>		0.20	1.0	%
Output Voltage change with Temperature Coef. (Note 6)	V <sub>OUT</sub> / T		<b>20</b>	<b>100</b>	ppm/°C
Dropout Voltage  (For 1.50 Version)  (For 1.80 Version)	V <sub>OUT</sub> - 1% (Note 3) I <sub>O</sub> = 100mA I <sub>O</sub> = 750mA I <sub>O</sub> = 1.0A		80 220 300	<b>200</b> <b>500</b>	mV
	I <sub>O</sub> = 100mA I <sub>O</sub> = 1.0A			<b>0.6</b> <b>0.8</b>	V
	I <sub>O</sub> = 100mA I <sub>O</sub> = 1.0A			<b>0.3</b> <b>0.5</b>	V
Ground Current	I <sub>O</sub> = 750mA, V <sub>IN</sub> = V <sub>OUT</sub> + 1V I <sub>O</sub> = 1.0A		8 22	<b>20</b>	mA
Ground Pin Current at Dropout I <sub>GNDDO</sub>	V <sub>IN</sub> = 0.5V less than specified V <sub>OUT</sub> , I <sub>OUT</sub> = 10mA, (Note 5)		0.9		mA
Current Limit	V <sub>OUT</sub> = 0V (Note 4)		2.1	<b>3.5</b>	A
Output Noise Voltage e <sub>n</sub> , (10Hz to 100Hz) I <sub>O</sub> = 100mA	C <sub>L</sub> = 10μF C <sub>L</sub> = 33μF		400 260		μV (rms)

**Note 1:** Maximum positive supply voltage of 60V must be of limited duration (<100msec) and duty cycle (≤ 1%).  
The maximum continuous supply voltage is 26V.

**Note 2:** Full Load current (I<sub>FL</sub>) is defined as 1.0A for the GM66102 series.

**Note 3:** Dropout voltage is defined as the input-to-output differential when the output voltage drops to 99% of its nominal value with V<sub>OUT</sub> + 1V applied to V<sub>IN</sub>

**Note 4:** V<sub>IN</sub> = V<sub>OUT</sub> (nominal) + 1V. For example, use V<sub>IN</sub> = 4.3V for a 3.3V regulator or use 6V for a 5V regulator. Employ pulse-testing procedures to minimize temperature rise.

**Note 5:** Ground pin current is the regulator quiescent current. The total current drawn from the source is the sum of the load current plus the ground pin current.

**Note 6:** Output voltage temperature coefficient is defined as the worst case voltage change divided by the total temperature range.

◆ TYPICAL CHARACTERISTICS GM66102

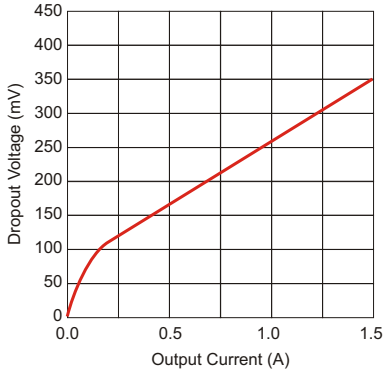

Figure 2. GM66102 Dropout Voltage vs. Output Current

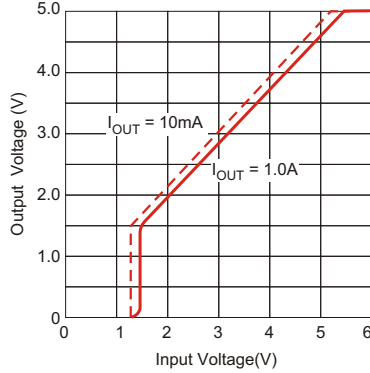

Figure 3. GM66102-5.0 Dropout Characteristics

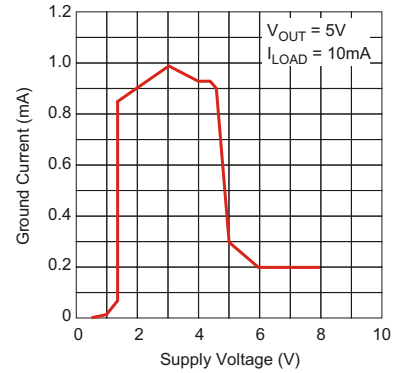

Figure 4. GM66102 Ground Current vs. Supply Voltage

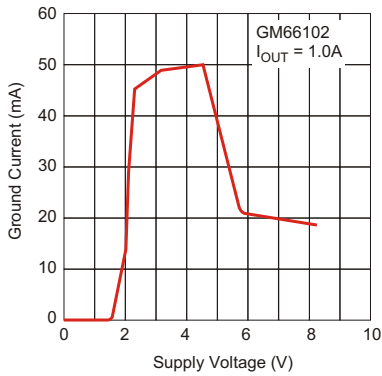

Figure 5. GM66102 Ground Current vs. Supply Voltage

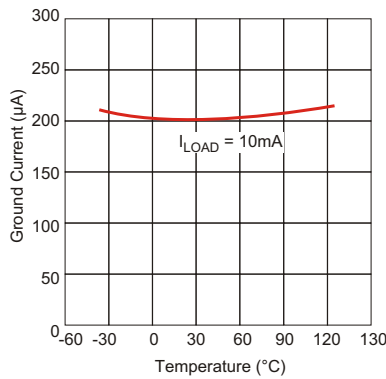

Figure 6. GM66102 Ground Current vs. Temperature

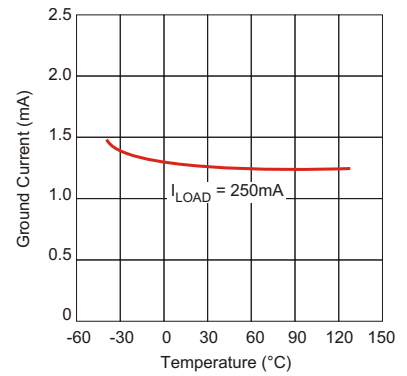

Figure 7. GM66102 Ground Current vs. Temperature

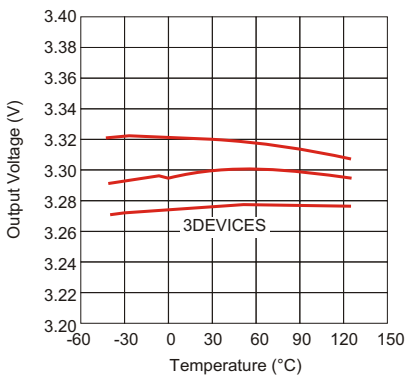

Figure 8. GM66102-3.3 Output Voltage vs. Temperature

#### ◆ APPLICATION INFORMATION

GM66102 series is high performance whit low-dropout voltage regulators, suitable for all moderate to high-current voltage regulator applications. Their 350mV dropout voltage at full load makes them especially valuable in battery powered systems and as high efficiency noise filters in "post-regulator" applications. Unlike older NPN-pass transistor designs, where the minimum dropout voltage is limited by the base-emitter voltage drop and collector-emitter saturation voltage, dropout performance of the PNP output of these devices is limited merely by the low  $V_{CE}$  saturation voltage. A trade-off for the low dropout voltage is a varying base drive requirement. But, Gamma's PNP process reduces this drive requirement to merely 1% of the load current. The GM66102 series of regulators are fully protected from damage due to fault conditions. Current limiting is provided. This limiting is linear and output current under overload conditions is constant. Thermal shutdown disables the device when the die temperature exceeds the 125°C maximum safe operating temperature. Transient protection allows device (and load) survival even when the input voltage spikes between -20V and +60V. When the input voltage exceeds about 35V to 40V, the overvoltage sensor temporarily disables the regulator. The output structure of these regulators allows voltages in excess of the desired output voltage to be applied without reverse current flow. An additional feature of this regulator family is a common pinout: a design's current requirement may change up or down by yet use the same board layout, as all of these regulators have identical pinouts.

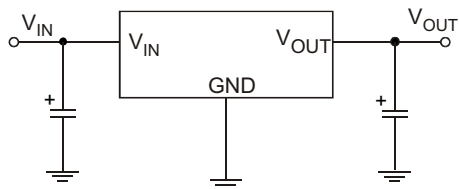

Figure 9. Linear regulators require only two capacitors for operation.

#### Thermal Design

Linear regulators are simple to use. The most complicated design parameters to consider are thermal characteristics. Thermal design requires the following application-specific parameters:

- Maximum ambient temperature,  $T_A$
- Output Current,  $I_{OUT}$
- Output Voltage,  $V_{OUT}$
- Input Voltage,  $V_{IN}$

First, we calculate the power dissipation of the regulator from these numbers and the device parameters from this formula:

$$P_D = I_{OUT} (1.01V_{IN} - V_{OUT})$$

where the ground current is approximated by 1% of  $I_{OUT}$ .

Then the heat sink thermal resistance is determined with this formula:

$$R_{SA} = \frac{T_{J(MAX)} - T_A}{P_D} (R_{JC} + R_{CS})$$

where  $T_{J(MAX)} \leq 125^\circ\text{C}$  and  $R_{CS}$  is between 0 and  $2^\circ\text{C/W}$ .

The heat sink may be significantly reduced in applications where the minimum input voltage is known and is large compared with the dropout voltage. Use a series input resistor to drop excessive voltage and distribute the heat between this resistor and the regulator, the low dropout properties of Gamma PNP regulators allow very significant reductions in regulator power dissipation and the associated heat sink without compromising performance. When this technique is employed, a capacitor of at least  $0.1\mu\text{F}$  is needed directly between the input and regulator ground.

◆ TO-252 PACKAGE OUTLINE DIMENSIONS

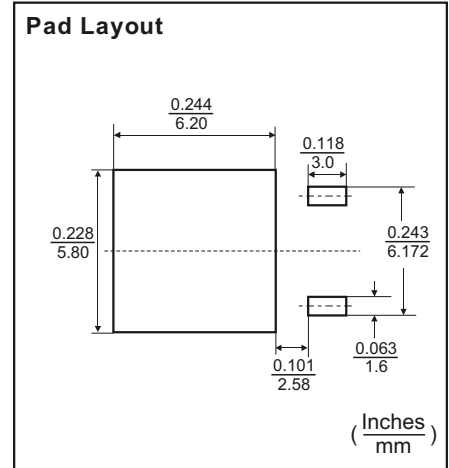
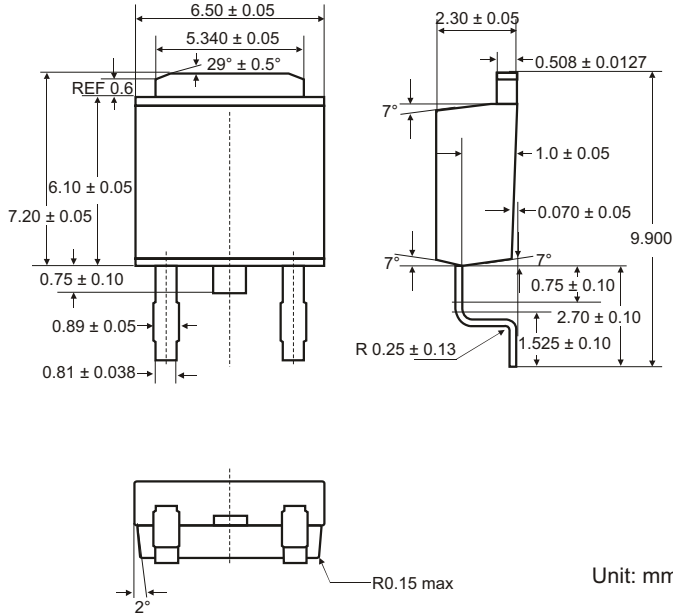

◆ TO-263-2 PACKAGE OUTLINE DIMENSIONS

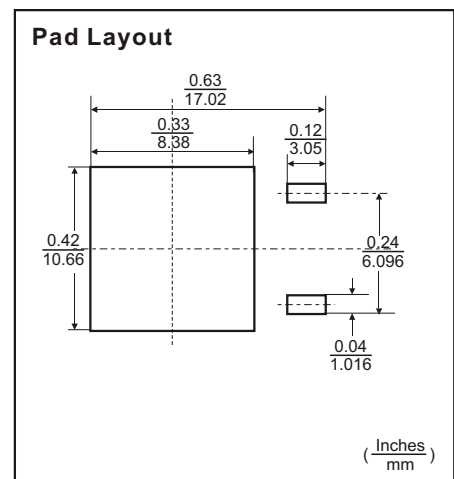
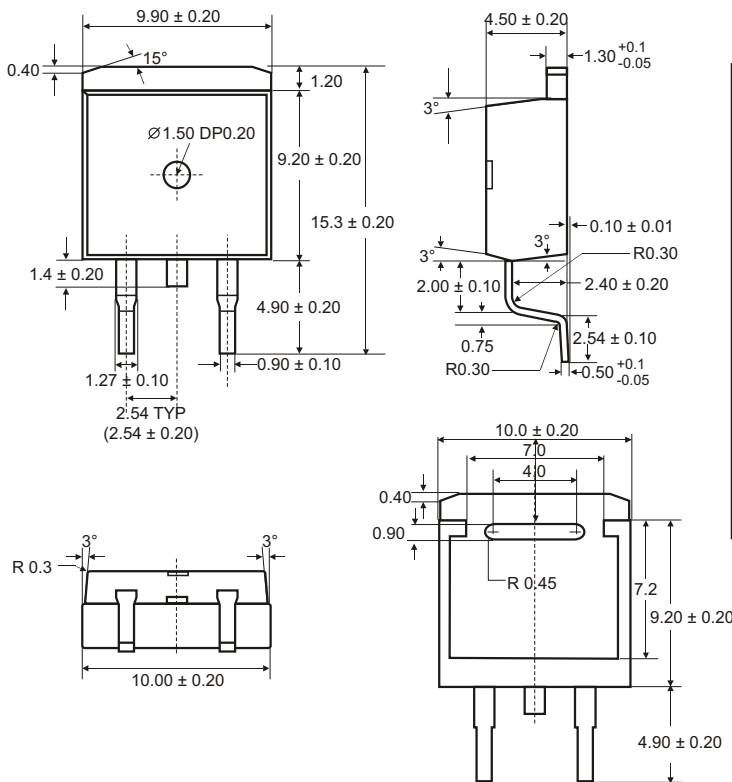



◆ TO-220 PACKAGE OUTLINE DIMENSIONS

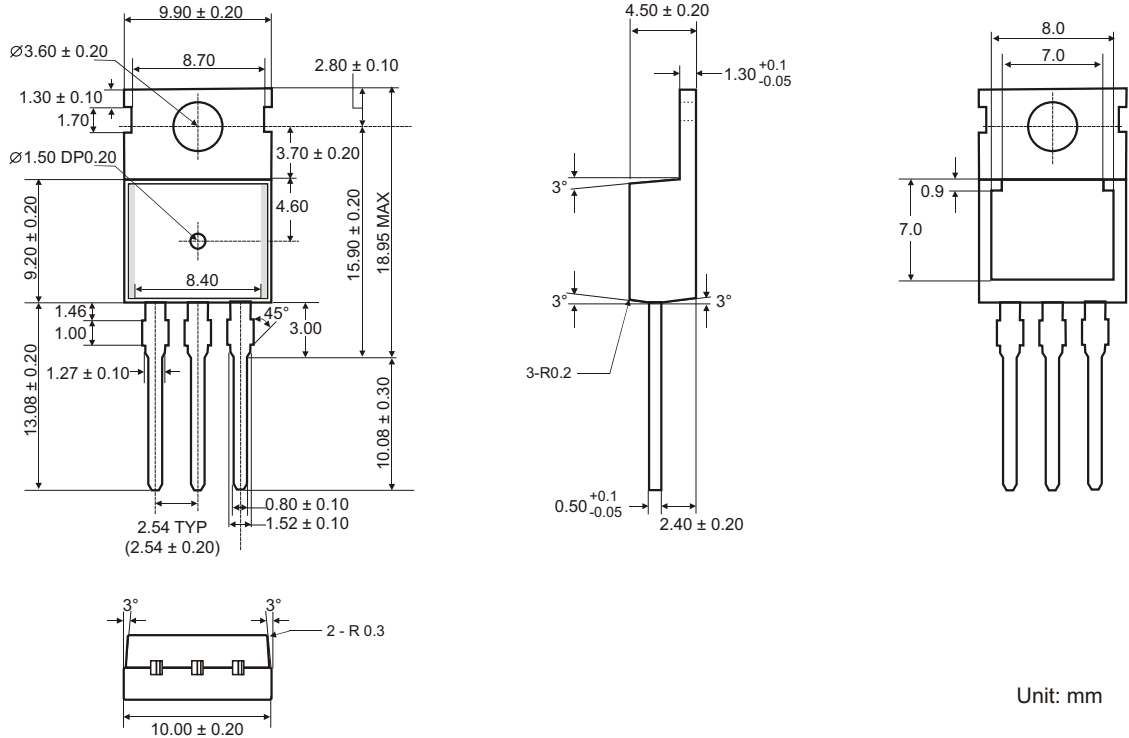

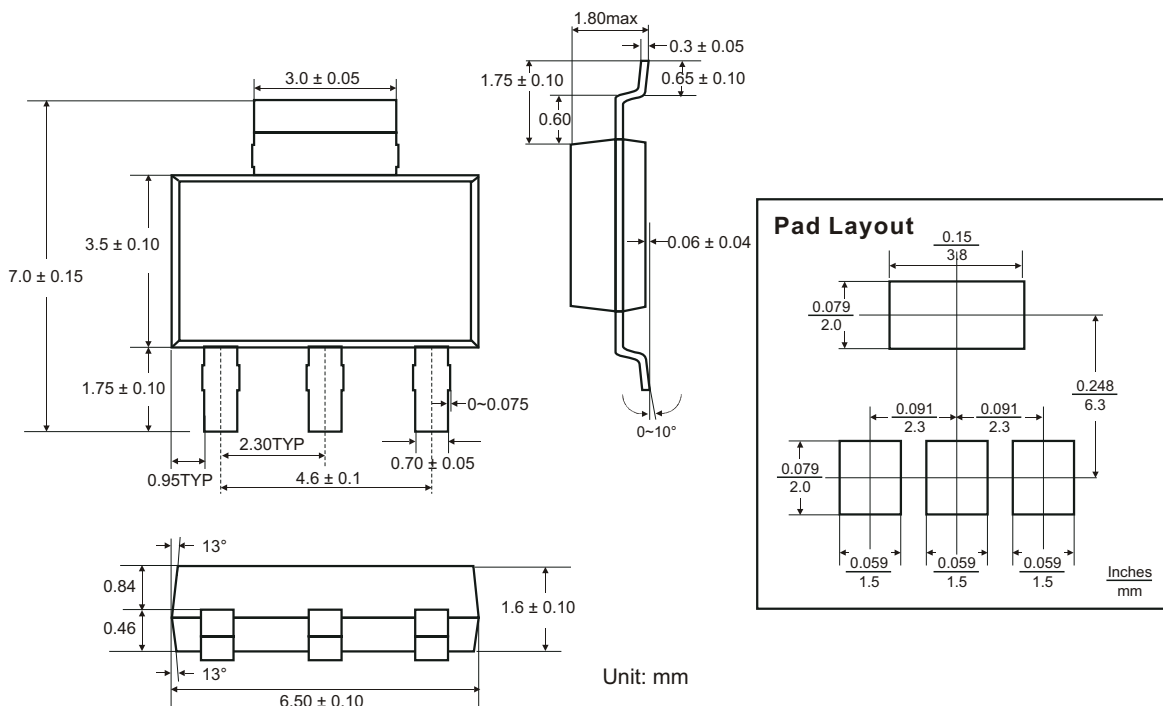

◆ SOT-223 PACKAGE OUTLINE DIMENSIONS

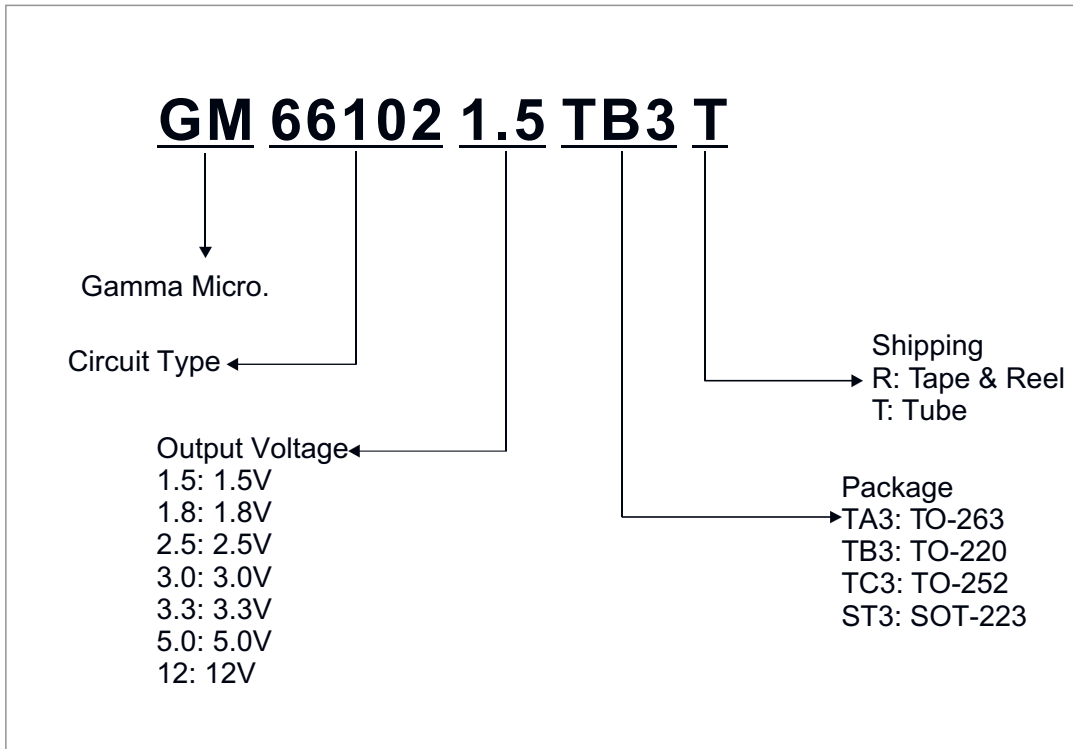

◆ ORDERING NUMBER



---

GAMMA Micro, , and  are registered trademarks of GAMMA MICROELECTRONICS INC. GAMMA reserves the right to make changes without further notice to any products herein. Information provided herein is alleged to be exact and consistent and this publication surpasses and replaces all information previously supplied.

GAMMA makes no warranty the suitability of its products for any particular purpose, nor does GAMMA assume any liability arising out of the application or use of any product or circuit, and specifically disclaims any and all liability including without limitation special, consequential or incidental damages.

GAMMA products are not authorized for using as critical components in life support devices or systems without prior written approval from GAMMA MICROELECTRONICS INC.

---